



M&D solutions

sliding gate valves

Murphy & Dickey works with the valve experts to ensure the very best solution for our clients. Call M&D today! www.murphyanddickey.com

Sliding Gate Valves

Sliding gate seats are used for modulating flows and on-off service.

The orifices in the plates break up the energy of the flow stream into easy to handle *packets*. The straight-through flow design is great for high noise applications and cavitating service. ANSI Class V shut-off provides years of reliable service. Metal-to-metal seats *wear in*, as opposed to *wearing out*.

Sliding gate valves are smaller and lighter than traditional control valves.

A 6-inch valve weighs only 48 pounds and stands 18 inches high! Thus, retrofitting into an existing application is easy.

For excellent rangeability consider the sliding gate valve. The forces within the valve operate perpendicular to the actuator, allowing very fine positioning for modulation. This gives the rangeability and pressure drop capability of a balanced cage-trim valve; with the economy of a globe valve. Gate valves are available in 1/2" to 8" designs, up to 1000°F at 1500 psi. with motorized and pneumatically actuated options.

Questions? Call M&D 630-655-1080.



How Sliding Gate Valves Work

A fixed sealing plate set in the body perpendicular to the direction of the flow has a number of slots and orifices of equal height across its face. A non-rotating disc, with the same slot configuration, slides vertically against it, thereby changing the flow direction. The pressure differential forces the moving disc against the fixed disc.

Simple, Yet Unique GS Valves:

- operate for millions of cycles
- wear *in* as opposed to wear *out*
- tight shut-off, self-lapping action
- lightweight for minimal space
- short stroke for high speed
- up to 1450 psi differential
- quiet operation, streamlined flow
- seats reduce turbulence & wear
- easy installation & maintenance
- high turndown: 100:1 to 300:1

Call M&D at 630-655-1080.

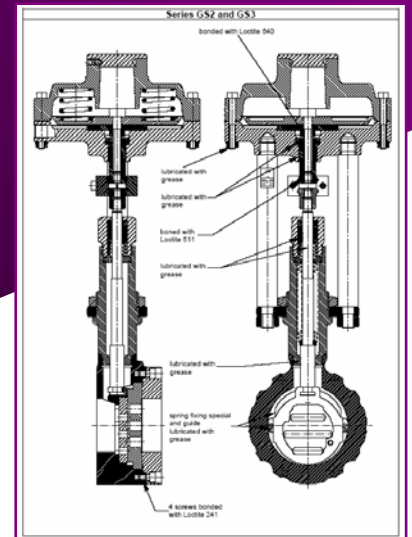

\$11.00 Shipping!

All orders shipped in the USA! Regardless of quantity or weight!



Murphy & Dickey, Inc.
930 N. York Road # 205
Hinsdale, IL 60521
630-655-1080 phone
630-655-1085 fax
sales@murphyanddickey.com