



# M&D solutions

## *dissolved oxygen*

DISSOLVED OXYGEN INSTRUMENTATION  
FOR PORTABLE & FIXED INSTALLATIONS

*Why does Murphy & Dickey represent Insite IG?  
Insite's staff is friendly and pleasant to work with.  
We can get application and order assistance quickly.  
Pricing is attractive and products are designed  
to work for a long time...*

## Awesome Sensor!

**Optical DO!** Insite did their homework here!  
Having sold a lot of DO systems over the years  
through smiles and tears, we are confident to make  
this claim: Insite has the best solution available  
today with a great price!

### Why Insite Offers A Superior Measurement

- Insite systems have an MTBF of 7 years.
- The unique sensor measures the fluorescence and quenching by oxygen of a patented ruthenium complex immobilized in a sol-gel matrix.
- Built-in TSS curves based on real-world data.
- All systems have a 5-year warranty.
- No consumables. No membranes or cartridges.
- Spare parts? 1 sensor per 15 systems at a facility. (A back-up probe, in case of physical damage.)
- No 6-12-month service package is required.
- Insite sensors do not break down in ambient light.

**Insite systems are simple.**

*Questions?*

*Call Murphy & Dickey, 630-655-1080*

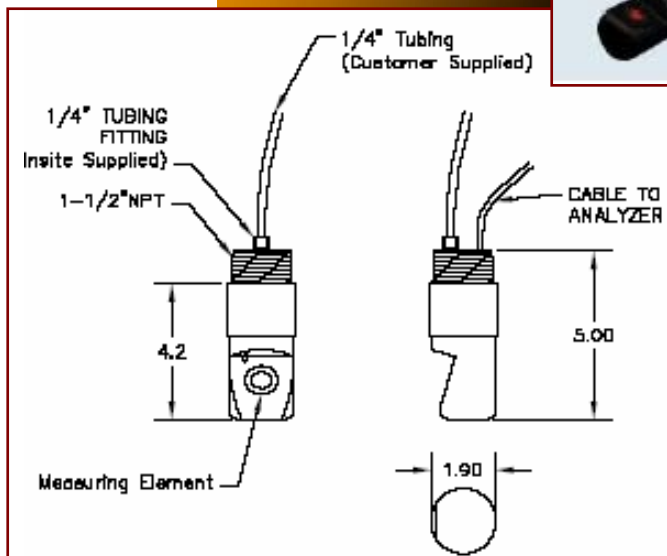

**Murphy & Dickey, Inc.**

930 N. York Road # 205

Hinsdale, IL 60521

630-655-1080 phone

630-655-1085 fax

sales@murphyanddickey.com

## PORTABLES TOO!

What do you like? Traditional membrane style, or fluorescent technology – Murphy & Dickey, Inc. has what you need! And how about personal safety monitors? We've got those too. If we don't have it, we know somebody that can get it...

[www.murphyanddickey.com](http://www.murphyanddickey.com)